

Features

- 1/2.9" SONY CMOS HD Colour Image Sensor
- Full 1080P (1920 x 1080) 25P / 30P
- 0.1 Lux ~ 0 Lux with IR
- Outstanding Picture Quality
- Housing High Grade Aluminium,
- Robust, Reliable & Versatile
- Smart IR LEDs
- IP69K Rated to stand up in the Harsh Environment
- Power DC 12V, 100mA
- Super Wide viewing angle 150°
- Built-in Microphone



Specification	CSP-406
Image Sensor	1/2.9" SONY CMOS Image Sensor
Resolution	1080p (1920 H x 1080 V) 25P / 30P
Min. Illumination	1.0 Lux, Colour 0 Lux BW with IR LEDs On
Pixel Pitch	2.8µm x 2.8µm
TV System	PAL / NTSC
Scanning System	Progressive Scanning
S/N Ratio	More than 52dB (AGC Off)
Video Output	AHD
AGC	Auto
Shutter Speed	Auto 1/30, 1/25 sec~1/50,000 sec
BLC	Auto
Gamma Consumption	0.45
Night Vision	Distance 5m
Day & Night	Automatic Adjustment
White Balance	Auto
Microphone	Yes
Current Consumption	Max 130mA
Power Source	Regulated 12 V DC (100mA) Max 1.2W
Lens	1.98mm Fixed Mega Lens
Lens Angle	Viewing Angle 150° Option Lens:130°,120°
IP Rated	Weather proof to IP69K Rated
Ant-Vibration	ISO 16750-3 (Max.17.3G)
Operating Temp	-20°C ~ 70°C RH95% Max
Connection	RCA / Female 4 Pin
Weight	Approx. 0.2 KG

Dimensions

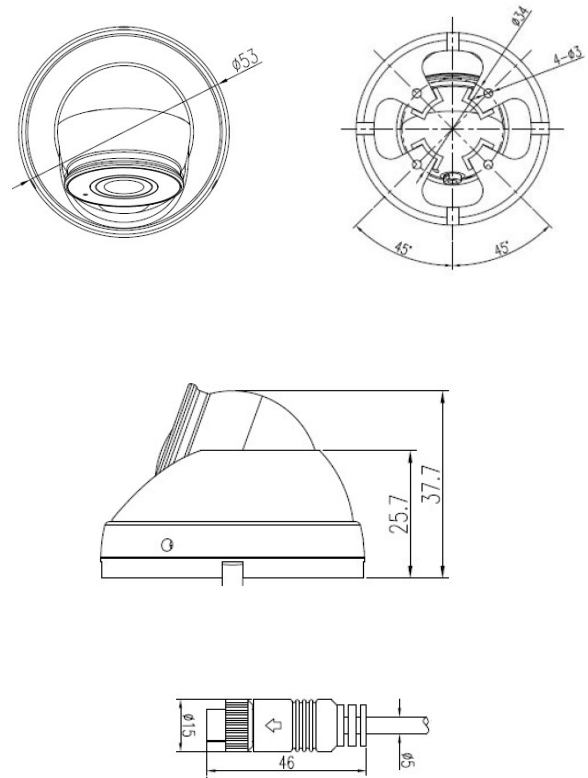

Description

The CSP406 One of the best tough compact mini cameras on the market, offering an outstanding Full 1080P picture quality with smart IR LED's for night vision. very impressive tough compact mini camera

The housing is made from high grade aluminum and is waterproof to IP69K making it ideal for harsh environments. It has a super wide viewing angle of 150° with a built-in microphone.

Looks great on the front, side or rear any of vehicles



Compact Camera
Code: CSP-406