

Mirror Replacement Camera System

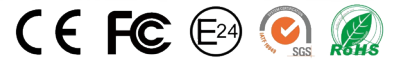

CSP-M-CAM

CE and E mark R46 Class II, and R46 Class IV, Certified

Increase visibility on your vehicles with CSP-MCAM our dual-camera mirror system.

Replacing your mirrors with HD 1080P cameras and HD monitor system allows you to have a greater view around your vehicle increasing the safety of you, your passengers and other road users.

Replacing your standard vehicle mirrors with a dual camera system can increase safety and reduce fuel consumption.

HD technology provides a sharp and detailed image in all conditions Day & Night Increase your driver's visibility manoeuvring around traffic and increase their confidence knowing they have the Full vision and safety of others.

CSP Technology Ltd, Unit 1 & 2 Moorwell Business Park,
Scunthorpe, North Lincolnshire, DN17 2RU

Tel: +44 (0) 1724 276557, Email: sales@c-s-p.co.uk Web: www.c-s-p.co.uk

Mirror Replacement Camera System

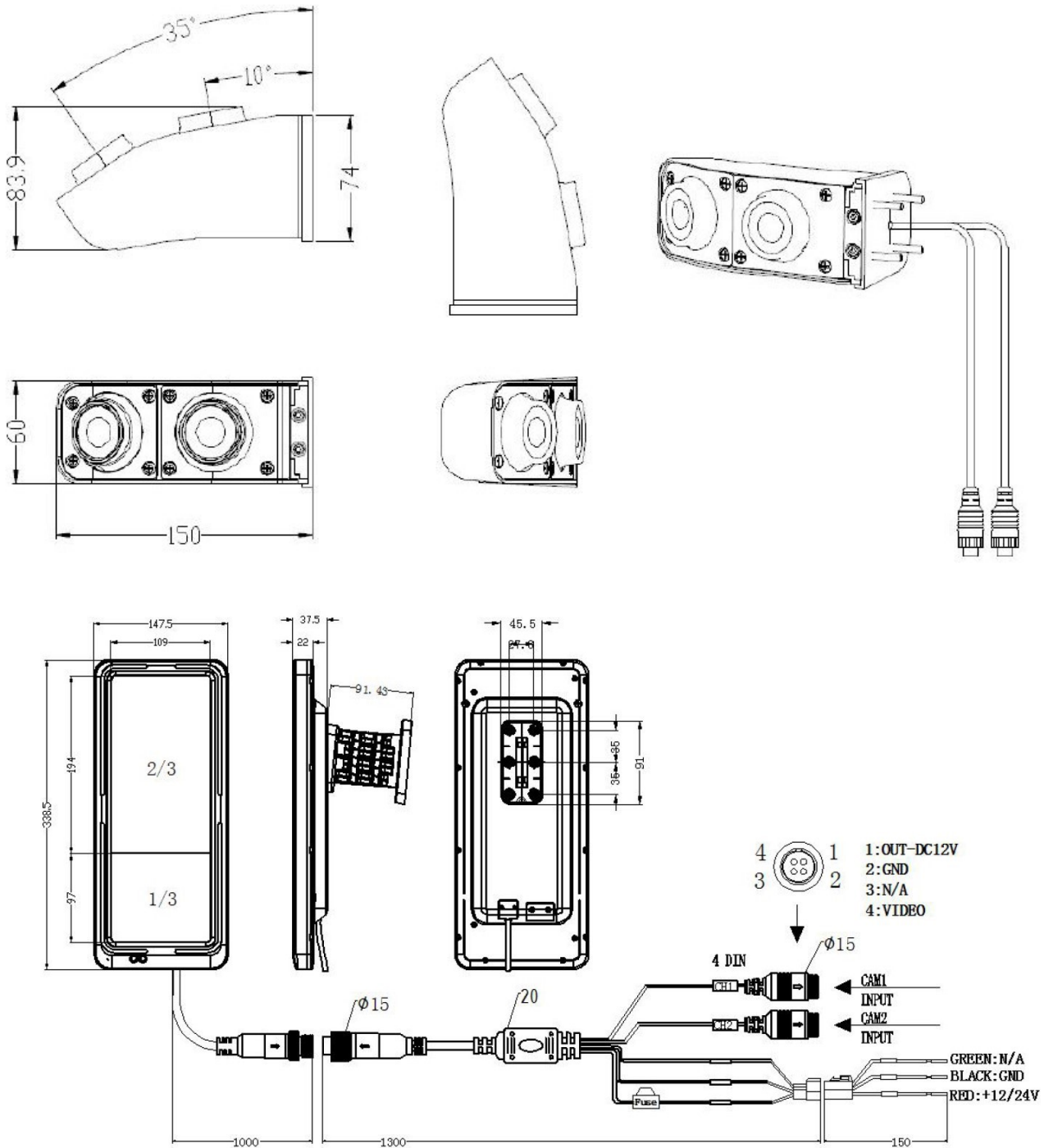

MONITOR

12.3 inch (8:3) IPS
 Monitor Size: 337.7 x 155 x 117.7mm
 Resolution: 1920 x 720 Vertical Screen
 Brightness 750cd/m2
 Power: DC12V-24V
 Max 25W
 Auto Brightness
 Remote Control Operation

CAMERAS

Camera 1 View, 1920*1080, F2.5 mm Megapixel
 Camera 2 View, 1920*1080, F12 mm Megapixel
 1080P /30FPS, PAL (NTSC Optional)
 Sony 307 HD Star Light Colour Night Vision Infrared LED's
 Auto Heating (Optional)
 Mirror Available, Supports WDR
 Anti-Fog, Anti-Glare, Anti-Rain
 IP 69k Waterproof, Dustproof
 Operating Temperature -30°C ~ +70°C